

Conveyors

Conveyor horizontal reach

Maximum at 0°	106' 1"	(32.34m)
Maximum at 30°	91' 6"	(27.91m)
Conveyor belt width	18"	(457mm)
Feed conveyor length	38'	(11.60m)
Feed conveyor belt width	18"	(457mm)
Trunk/end hose length	15'	(4.57m)

Discharge height from grade

Maximum at 30°	60' 2"	(18.36m)
Maximum at -15°	-20'	(-6.11m)

Rated capacity at 0°

main & feed conveyors	360 yd ³ /hr	(275m ³ /hr)
-----------------------	-------------------------	-------------------------

Rated capacity up to 20°

main & feed conveyors	230 yd ³ /hr	(175m ³ /hr)
-----------------------	-------------------------	-------------------------

Maximum theoretical values listed.

Outriggers

Net reach beyond outriggers

at 0°	100' 6"	(30.65m)
at 30°	86'	(26.23m)

Outrigger spread

front, swing out hydraulic up/down	23' 1"	(7.05m)
rear, swing out hydraulic up/down	26' 9"	(8.17m)

General Specifications

Water tank capacity	200 gal	(757L)
---------------------	---------	--------

Hydraulic oil tank capacity

with cooler	150 gal	(568L)
-------------	---------	--------

Truck Specifications^{••†}

Weight	20,015 lbs	(9,078kg)
Engine horsepower	400 hp	(300kW)
Wheelbase	287"	(7,290mm)
Cab height	104"	(2,642mm)
Steering radius (outside)	45' 6"	(13.87m)
Steering angle	30°	
Fuel tank capacity	80 gal	(416L)
Transmission	Mack T309LR 9-Speed	

Transport Axle Weights^{••†}

Steering	19,253 lbs	(8,733kg)
Pusher	11,000 lbs	(4,989kg)
Tandem	31,274 lbs	(14,185kg)
Total	61,527 lbs	(27,907kg)

* Truck dimensions will vary with different truck makes, models and specifications.

• Weights are approximate and include conveyor truck, full hydraulic oil, fuel, driver and 100 gal (379L) of water.

† All specifications apply to units mounted on Mack MR 688S.

Telebelt® TB 110

Telescopic Belt Conveyor



- Places materials from sand to 4" (100mm) rock
- Smooth surge-free conveying results
- Sets up under low 15' 9" (4.80m) heights
- 106' 1" (32.34m) horizontal reach

TB 110

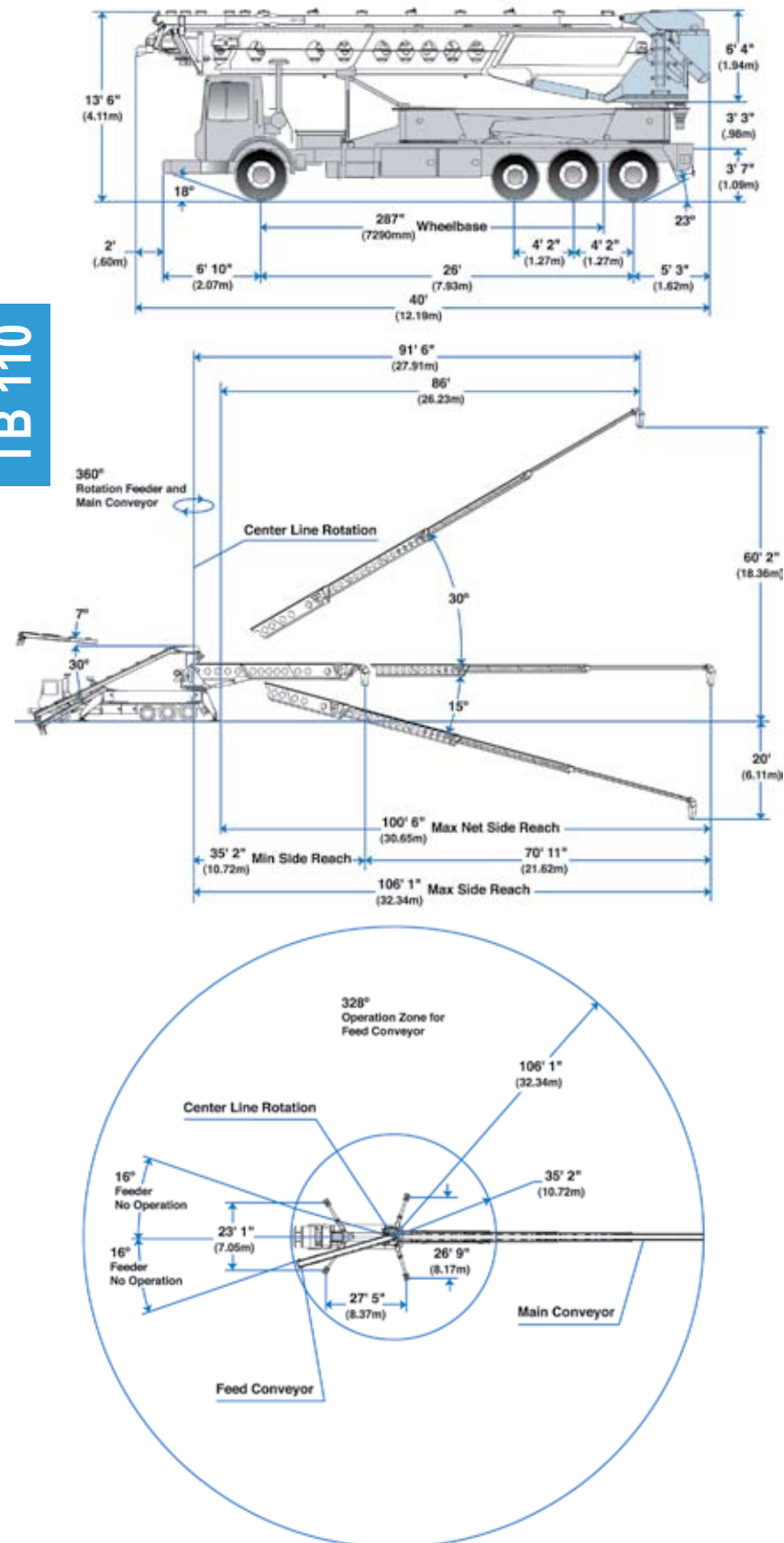

Photos and drawings are for illustrative purposes only.

Conveyors

Conveyor horizontal reach		
Maximum at 0°	106' 1"	(32.34m)
Maximum at 30°	91' 6"	(27.91m)
Conveyor belt width	18"	(457mm)
Feed conveyor length	38'	(11.60m)
Feed conveyor belt width	18"	(457mm)
Trunk/end hose length	15'	(4.57m)
Discharge height from grade		
Maximum at 30°	60' 2"	(18.36m)
Maximum at -15°	-20'	(-6.11m)
Rated capacity at 0°		
main & feed conveyors	360 yd ³ /hr	(275m ³ /hr)
Rated capacity up to 20°		
main & feed conveyors	230 yd ³ /hr	(175m ³ /hr)
Maximum theoretical values listed.		

Outriggers

Net reach beyond outriggers		
at 0°	100' 6"	(30.65m)
at 30°	86'	(26.23m)
Outrigger spread		
front, swing out hydraulic up/down	23' 1"	(7.05m)
rear, swing out hydraulic up/down	26' 9"	(8.17m)

General Specifications

Water tank capacity	200 gal	(757L)
Hydraulic oil tank capacity		
with cooler	150 gal	(568L)

Truck Specifications**+

Weight	20,015 lbs	(9,078kg)
Engine horsepower	400 hp	(300kW)
Wheelbase	287"	(7,290mm)
Cab height	104"	(2,642mm)
Steering radius (outside)	45' 6"	(13.87m)
Steering angle	30°	
Fuel tank capacity	80 gal	(416L)
Transmission	Mack T309LR 9-Speed	

Transport Axle Weights**+

Steering	19,253 lbs	(8,733kg)
Pusher	11,000 lbs	(4,989kg)
Tandem	31,274 lbs	(14,185kg)
Total	61,527 lbs	(27,907kg)

* Truck dimensions will vary with different truck makes, models and specifications.
 • Weights are approximate and include conveyor truck, full hydraulic oil, fuel, driver and 100 gal (379L) of water.
 + All specifications apply to units mounted on Mack MR 688S.



Putzmeister America
 1733 90th Street
 Sturtevant, WI 53177 USA
 Telephone (262) 886-3200
 (800) 884-7210
 Facsimile (262) 884-6338
 www.putzmeister.com



Authorized Distributor

Putzmeister TELEBELT® ADVANTAGE



Low Clearance Projects

With extremely low unfolding heights and the ability to be moved rapidly, Putzmeister Telebelts® can be set up and operated on jobs with height restrictions such as warehouse slabs. Material can be conveyed long distances in an enclosed structure, under bridges and into limited access structures.



Handles Various Materials

In addition to handling aggregates from rock to sand with ease, a Telebelt® conveys a multitude of concrete mix designs. Separation and loss of air entrainment are not an issue with conveyed concrete. This makes them a great choice for critical mix designs.



Saves Time & Labor

Need to place gravel and concrete on the same site in the same day? Telebelts® can perform multiple tasks from a single location. Quick setup and tear down as well as the ability to place material at high volumes enable you to complete more jobs with less manpower. Tedious tasks once requiring multiple trips with other equipment are eliminated.

Telebelt® TB 110

Telescopic Belt Conveyor Standard Features

Boom

- 106' 1" (32.34m) horizontal reach
- Low 15' 9" (4.80m) unfolding height
- Four-section telescopic boom with second and third boom section synchronization
- Steel/aluminum base with three telescopic high strength aluminum sections
- Single control lever to extend/retract all boom sections
- Maintenance free sealed roller bearings
- Quick telescoping feature
- 360° hydraulic rotation

Main Conveyor

- 18" (457mm) 3-ply nylon core vulcanized spliced belt with hot melt and no staples or mechanical splices
- Maximum rated 360 cubic yards an hour (275m³/hr)
- Infinitely variable belt speed control from 0 to 100%
- Spring-tensioned carbide scraper system
- Active independent control of the feed and main conveyor systems

Feeder Belt

- 38' (11.60m) aluminum independent hydraulic feed conveyor
- 360° hydraulic rotation allowing material to be loaded from any position desired
- 18" (457mm) belt can be fed by a ready mix truck, dump truck, skid-steer loader or front-end loader
- UHMW polyethylene integrated folding feeder hopper handles the toughest mixes
- Spring-tensioned carbide scraper system

Boom Control & Operation

- Main conveyor functions controlled by Modular Boom Control (MBC) system
- Single-section maintenance without removing entire valve assembly
- Ergonomic and lightweight standard proportional radio remote control
- Independent belt speed control for main and feed conveyors
- 100' (30m) proportional cable remote included (available January 2006)
- Manual control backup for all functions

Trunk/End Hose

- Standard 8" (200mm) and 12" (305mm) tremie reducers – each with 15' (4.57m) end hoses and chain binder

Material Handling

- Handles harsh concrete mixes of any slump consistently
- No special mix requirements
- Places any type of flowable material

Power

- Driven by two full horsepower rated air shift rear PTOs from the Mack MR 688S 400 hp (300kW) engine
- Low engine RPM and 150 hp (112kW) for reduced fuel costs

Outriggers

- Quick and easy setup in congested areas
- Compact footprint
- Sets up on solid or rough terrain
- Unique "butterfly" design outriggers manually swing out and hydraulically extend up or down

Clean Out

- Requires only water to clean feeder hopper and belt
- High pressure 2,500 psi (173 bar) hydraulically-driven pressure washer system
- Large capacity 200 gal (757L) water tank

Additional Standard Features

- Aluminum diamond deck
- Large side-mounted aluminum tool boxes
- Emergency stop buttons
- High quality paint finish
- Operators manuals and ship-away kit
- Air-activated pusher axle ensures compliance with federal bridge formula weight requirements in most states

Available Options

- Rock hopper
- Front-end loader hopper
- Low profile hopper
- Side loading channels
- Oil/water tank heaters
- Custom paint schemes

Consult factory for options not listed.

Putzmeister
PRO-VANTAGE
WARRANTY PLAN

The PRO-VANTAGE Warranty Plan extends the coverage on all Putzmeister Telebelts® for a total of 36 months or 6,600 hours at no extra charge.



Use Your Imagination!

Telebelts® are ideal for countless applications including:

- Tilt-Up Panels
- Basements
- Foundations/Footings
- Mat Pours
- Backfill
- Bridge Decks
- Slope Paving
- Low Height Areas
- Slabs
- Landscaping
- Dams
- Environmental Projects

Putzmeister TELEBELT® ADVANTAGE



Placement Versatility

A Telebelt® offers a quick way to easily clear obstacles and place material exactly where you want it without the need for all-wheel drive mixer trucks, skid-steer loaders or other equipment. Ideal for maneuvering around a variety of job sites including mat pours, backfilling, tilt-up projects, bridge decks and slab work.



A Cleaner, More Efficient Site

Telebelts® do not require priming and all material can be run off the belts eliminating waste. A highly efficient spring-tensioned carbide scraper system helps to keep job sites clean.



Setup Convenience

An integral part of the feed conveyor, the folding hopper makes setup a breeze. Side panels fold into the feed conveyor and end panels connect with linchpins. The belt can then be easily fed with a ready mix truck from three sides. Optional hoppers are also available for use with a skid-steer loader, front-end loader or coal chute.